

95 and 89 kcal./mole, respectively. Their calculation was based on the incorrect assumption that the CO bond energy is the same in $\text{Fe}(\text{CO})_5$ as in $\text{Ni}(\text{CO})_4$. The Raman spectrum of $\text{Fe}(\text{CO})_5$ indicates that this assumption is not justified. Also, they had no effective means of estimating the CO bond energy from that of carbon monoxide. The Fe-C and Ni-C bond energies calculated here are of the same order of magnitude as bond energies calculated for Sn-C and Pb-C, indicating that the Fe-C and Ni-C bonds must have a bond order only slightly larger than 1.¹⁶ This result is consistent with the values for the Sn-C, Pb-C, Zn-C and

Cd-C bond stretching force constants which have values of 2.37, 1.94, 2.39 and 2.05×10^7 dynes/cm., respectively.¹⁸

NOTE ADDED IN PROOF.—We have recently made detailed calculations of the valence force symmetry coordinates (VFSC) and valence force coordinates (VFC) for $\text{Fe}(\text{CO})_5$ using the Wilson FG technique and the above assignment of frequencies. We calculate for the axial and equatorial Fe-C bond stretching VFC the values 3.06×10^6 and 3.29×10^6 dynes/cm., respectively.

This work was supported in part by the U. S. Atomic Energy Commission.

(18) R. K. Sheline, *J. Chem. Phys.*, **13**, 602 (1959).
COLLEGE PARK, MD.

[CONTRIBUTION FROM U. S. NAVAL ORDNANCE TEST STATION]

Dipole Moment Measurements of Tetrazole Derivatives

BY MARTIN H. KAUFMAN, FRED M. ERNSBERGER AND WILLIAM S. MCEWAN

RECEIVED DECEMBER 27, 1955

Dipole moments have been measured for a variety of tetrazole derivatives. It has been established that such measurements are not suitable for recognizing "meso-ionic" compounds.

Introduction

Henry, Finnegan and Lieber¹ recently reported the preparation of 1,3-dimethyl-5-iminotetrazole, a cyclic "meso-ionic" compound. It was anticipated² that the reaction of 2-methyl-5-aminotetrazole with methyl benzenesulfonate, according to the procedure of Herbst, Roberts and Harvill,³ would result in the formation of the 1,2-dimethyl derivative. However, a preliminary X-ray analysis of the hydrobromide salt of the resultant compound² and a modified three-dimensional Fourier synthesis by Bryden⁴ demonstrated unambiguously that the compound was the cyclic "meso-ionic" 1,3-dimethyl-5-iminotetrazole.

A complete X-ray analysis will lead to an accurate structure; however, it is not generally applicable to all compounds. The purpose of this investigation was to see what information about the structure of tetrazoles could be obtained from dipole moment measurements and whether it was possible to recognize "meso-ionic" compounds by such measurements.

Experimental

Materials and Methods.—Mallinckrodt, analytical reagent grade benzene was purified by crystallizing twice and then fractionally distilling after standing several days over freshly cut and ribboned sodium. All was rejected but the center cut which was redistilled in the same manner before use. The specific volume parameter for the solvent was obtained for each run from a least-squares examination of the specific volume, weight fraction data and was found to be constant to $\pm 0.02\%$.

Tetrazoles.—These were obtained, fairly pure, from Drs. R. A. Henry and W. G. Finnegan. The solids were sublimed once immediately prior to each run. The liquids, small quantities of which were available, were distilled through a Vigreux column before use.

(1) R. A. Henry, W. G. Finnegan and E. Lieber, *THIS JOURNAL*, **76**, 2894 (1954).

(2) J. H. Bryden, *et al.*, *ibid.*, **75**, 4863 (1953).

(3) R. Herbst, C. Roberts and E. Harvill, *J. Org. Chem.*, **16**, 139 (1951).

(4) J. H. Bryden, *Acta Cryst.*, **8**, 211 (1955).

Dielectric Constants.—These were measured with a Leeds and Northrup Company capacitance and conductance bridge using No. 1553 shielded ratio box. The dielectric constant cell consisting of three concentric cylinders of brass tubing was similar in design to the measuring condenser of Snyth and Morgan.⁵ The assembly was sealed into an annular "Pyrex" glass cylindrical vessel. The annular space reduced the quantity of solution required and aided in the circulation of the thermostated kerosene. The apparatus was calibrated with benzene, the dielectric constant of which was taken to be 2.2750 at 25°.⁶

Specific volumes were determined with a 25-ml. "Weld" specific gravity bottle with which specific gravities can be determined to within 0.001%.

Refractive indices were measured with a "Spencer Abbe" refractometer. The pure benzene was taken to have a standard refractive index of 1.5002.

Calculation of Moment.—The following nomenclature has been used throughout this paper. W_2 is the weight fraction of the solute, ϵ the dielectric constant of the solution, V its specific volume. P_∞ is the solute polarization at infinite dilution, R_2 is the molar refraction of the solute for the D-sodium line. ϵ_1 and V_1 , the dielectric constant and the specific volume of the solvent, respectively, are the intercepts while α and β are the slopes of the straight lines obtained by plotting ϵ and V against W_2 , respectively.⁷

$$\epsilon = \epsilon_1 + \alpha W_2 \quad (1)$$

$$V = V_1 + \beta W_2 \quad (2)$$

The derived data, obtained from the experimental data by the method of least squares, are presented in Table I with the slopes of the above lines, along with solute polarizations at infinite dilution calculated from the Halverstadt and Kuinler⁸ relationship.

$$P_\infty = \frac{3\alpha V_1 M_2}{(\epsilon_1 + 2)^2} + M_2(V_1 + \beta) \frac{(\epsilon_1 - 1)}{(\epsilon_1 + 2)} \quad (3)$$

Included also in Table I is the molar refraction of the solute for the D-sodium line calculated from

$$R_2 = \frac{R_{1,2} - R_1}{X_2} + R_1 \quad (4)$$

where R is molar refraction, X is mole fraction and subscripts 1, 2, 1,2 indicate solvent, solute, solution, respec-

(5) C. P. Smyth and S. O. Morgan, *THIS JOURNAL*, **50**, 1747 (1928).

(6) A. S. Brown, P. M. Levin and E. W. Abrahamson, *J. Chem. Phys.*, **19**, 1223 (1951).

(7) G. Hedestrand, *Z. physik. Chem.*, **B2**, 438 (1929).

(8) I. F. Halverstadt and W. D. Kuinler, *THIS JOURNAL*, **64**, 2988 (1942).

TABLE I
 CALCULATED DATA

Tetrazole	ϵ_1	V_1	α	β	P_∞	R_2	μ
1-Phenyl-5-methyl-	2.2801	1.14527	22.25	-0.34	706.0	56.3	5.64
1,5-Diphenyl-	2.2785	1.14536	17.85	-.34	798.8	76.2	5.95
1,5-Dimethyl-	2.2879	1.14505	31.51	-.32	603.2	27.3	5.30
1-Methyl-5-phenyl-	2.2711	1.14557	22.46	-.34	718.2	53.3	5.70
1-Ethyl-	2.2740	1.14501	32.85	-.29	631.1	22.9	5.46
2-Ethyl-	2.2877	1.14531	8.00	-.22	173.9	30.2	2.65
1-Ethyl-5-ethylamino-	2.2689	1.14543	41.43	-.42	1147.9	30.7	7.36
1-Butyl-5-butylamino-	2.2751	1.14480	27.81	-.16	1088.7	53.7	7.12
2-Methyl-5-methylamino-	2.2796	1.14528	5.82	-.31	151.9	19.1	2.55
1,3-Dimethyl-5-amino-	2.3186	1.14440	16.62	-.34	373.9	44.3	4.02
1,4-Dimethyl-5-imino-	2.2824	1.14523	2.66	-.26	89.4	34.1	1.65
1,4-Dimethyltetrazalone	2.2804	1.14539	1.35	-.35	56.2	29.1	1.14

tively. The dipole moment, μ , was calculated from the Debye equation

$$\mu = 0.01281 \times 10^{-18} [(P_\infty - R_2)T]^{1/2} \quad (5)$$

where T is the absolute temperature.

Precision of the Measurements.—The slopes and intercepts were obtained by the method of least squares

$$\left[\frac{\sum \epsilon W_2 - \frac{\sum \epsilon \sum W_2}{n}}{\sum W_2^2 - \frac{(\sum W_2)^2}{n}} \right] = \alpha \quad (6)$$

and

$$\frac{\sum \epsilon}{n} - \frac{\alpha \sum W_2}{n} = \epsilon_1 \quad (7)$$

respectively.

The scatter of points about the ϵ , W_2 plots was often as large as 0.001 unit of dielectric constant and as low as 0.0002 for the more easily purified samples. The larger scattering generally occurred with the liquids 1-ethyltetrazole and 2-ethyltetrazole as well as 1,4-dimethyl-5-iminotetrazole. The small quantities available made high purification of these materials rather difficult. On the average, the scatter about V vs. W_2 plots was 0.00006 unit of specific volume.

Discussion and Results

The term "meso-ionic" was coined by Baker, *et al.*,⁹ to identify compounds, exhibiting aromatic characteristics, which can be represented only as resonance hybrids of a large number of contributing ionic forms. They cannot be represented by one covalent formula, or as a hybrid of a number of covalent formulas, while most organic compounds can be represented quite satisfactorily by one covalent form or a hybrid of a few covalent forms. The vector addition of moments of the extreme forms partially cancel each other due to the moments acting in opposite directions, the observed moments being quite a bit lower than that required for any of the extreme forms.

For the case of the "sydnones," described by Hill and Sutton,¹⁰ the mesomeric moments augment the primary moments causing resultants of a high order. The real forms of the "sydnones" must be considered as intermediate between a large number of strongly polar extreme structures.

We shall attempt to show that in the tetrazole system augmentation or reduction of the primary moment can be effected by changing the position of substitution. The dipole moment of 1,3-dimethyl-5-iminotetrazole, a meso-ionic compound, is less than that of some tetrazoles for which a purely covalent structure can be drawn. Assuming the

(9) W. Baker, W. D. Ollis and V. D. Poole, *J. Chem. Soc.*, 310 (1949).

(10) R. A. W. Hill and L. E. Sutton, *ibid.*, 746 (1949).

structural assignments are correct, this precludes the use of dipole moments to identify purely "meso-ionic" compounds.

Tetrazole can conceivably occur as either of the tautomers I and II. Some of the resonant electronic structures for tautomer I are shown as III-VII, and some of the resonance structures for II are shown as VIII-X.

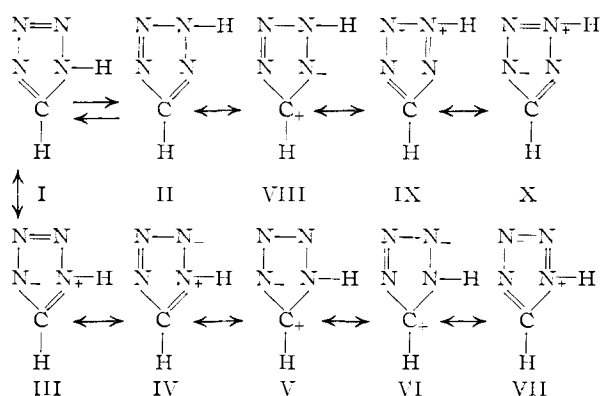

This compound has a K_a ¹¹ value of 1.28×10^{-5} and a dipole moment¹² of 5.11 D . Resonance structures like III, IV and VII will contribute to the stability of both the neutral molecule and the anion resulting from ionization. However, these contributions will be greater for the anion because of the symmetry of the situation and because of the absence of a formal positive charge on nitrogen two for these structures in the anion. These considerations, which are analogous to those that apply in the case of pyrrole, account for the large acid constant of tetrazole.

The dipole moment of 2-ethyltetrazole is 2.65 D , while that of 1-ethyltetrazole is 5.46 D , which would imply that the tetrazole represented by structure I predominates.

Some of the structures which can be drawn as resonance hybrids for 2-ethyltetrazole (XI-XV), 1-ethyltetrazole (XVI-XXI), 2-methyl-5-methylaminotetrazole (XXII-XXIII) and 1-ethyl-5-ethylaminotetrazole (XXIV-XXVI) are shown below.

Where R = methyl; 2-methyl-5-methylaminotetrazole ($\mu = 2.55 D$). Structures similar to those of 2-ethyltetrazole have been omitted and will be re-

(11) E. Oliveri-Mandala, *Gazz. chim. ital.*, **44** [11], 175 (1914).

(12) K. A. Jensen and A. Friediger, *Kgl. Danske Videnskab. Selskab. Math.-fys. Medd.*, **20**, No. 20, 1 (1943).

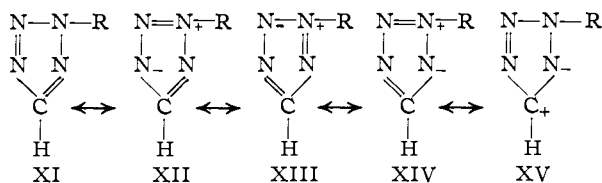

Where R = ethyl; 2-ethyltetrazole ($\mu = 2.65 D$)

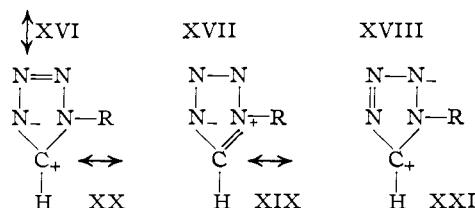
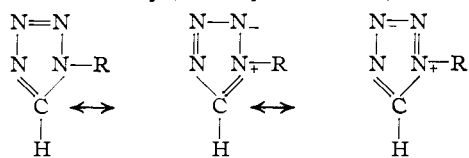

Where R = ethyl; 1-ethyltetrazole ($\mu = 5.46 D$)

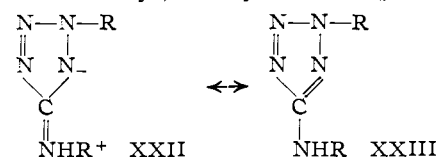

ferred to by inserting a lower case "a" with the Roman numeral of 2-ethyltetrazole, e.g.

XIIa would be

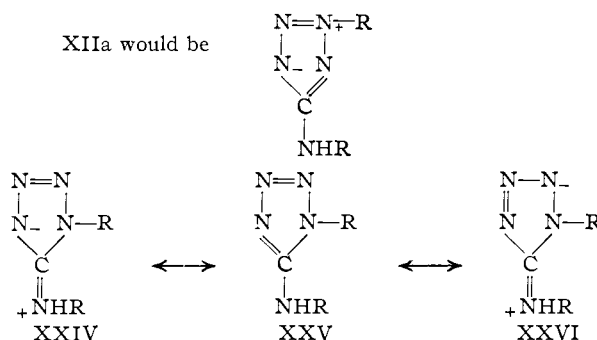

Where R = ethyl; 1-ethyl-5-ethylaminotetrazole ($\mu = 7.36 D$).

As with 2-methyl-5-methylaminotetrazole a lower case "a" will refer to omitted structures corresponding to those depicted for 1-ethyltetrazole.

In general, only those structures which we believe to contribute most significantly to the structure of the molecule have been displayed above. For example, structures with a formal negative charge on the ring carbon atom have been omitted.

From the resonance structures of tetrazole tautomer I and 1-ethyltetrazole (XVI), in view of the preponderance of drawings which have a positive charge in the vicinity of carbon, one may suggest that the positive end of the dipole moment resides in the neighborhood of the ring carbon atom and that the negative end is somewhat directed toward nitrogens two and three.

A discussion of 1-ethyltetrazole and the 1-ethyl-5-amino derivative is straightforward. The additional structures XXIV and XXVI augment the

moment of 1-ethyltetrazole. Thus, 1-ethyl-5-ethylaminotetrazole's moment is $7.36 D$ compared with 5.46 for 1-ethyltetrazole, while the direction of these molecule's moments are somewhat the same.

The dipole moment of 2-ethyltetrazole is $2.65 D$. The positive charges on nitrogen two (XII, XIII and XIV) have a resultant moment directed somewhere between nitrogen four and the ring carbon, whereas structure XV, which is important for any (C=N) containing compound, has a moment in a more or less opposite direction. These same structures are important for the case of 2-methyl-5-methylaminotetrazole, but in addition structure XXII must be considered.

A possible *ad hoc* treatment of the above data can be carried out as follows. Considering 2-ethyltetrazole, if the resultant of the $-N-N^+$ bond moments (XII-XIV) is at an angle of, say, 52° with

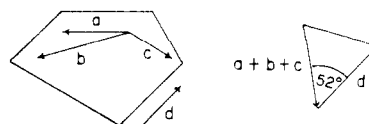

respect to the $+C-N^-$ bond moment (XV) and both of these vectors are of equal magnitude, say $3 D$, then the magnitude of this resultant would be approximately $2.6 D$. Then, providing the angle between the moment of 2-ethyltetrazole and the moment of structure XXII is close to 115° , the resultant of these two vectors, *i.e.*, the moment of 2-alkyl-5-alkylaminotetrazole, would be about equal to the moment of 2-alkyltetrazole but in a somewhat opposing direction.

A similar but more mathematical approach may be as follows. Let μ_a be the amino group moment. Using the approximate additivity of dipole moments, the relative directions of the moments of 1-ethyl- and 2-ethyltetrazole may be determined following the method described by C. P. Smyth.¹³

For convenience, in the following drawings straight lines have replaced the nitrogen ring system.

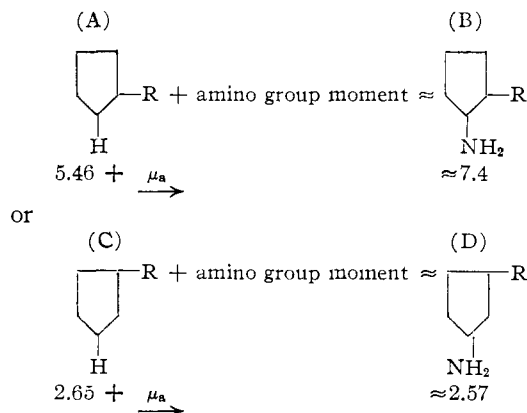

(A) is 1-ethyltetrazole, (B) is 1-ethyl-5-aminotetrazole, assuming that the value of its dipole moment will be close to that of 1-ethyl-5-ethylaminotetrazole, (C) is 2-ethyltetrazole and (D) is 2-ethyl-5-aminotetrazole.

(13) A. Weissberger, "Physical Methods of Organic Chemistry," 2nd Ed., Interscience Publishers, Inc., New York, N. Y., Chapter XXIV, 1949, p. 1615.

We choose our coordinates so that $\vec{\mu}_a$ is in a positive direction. Certainly, $\mu_a < 7.4$, therefore, $\cos \theta_A$ (the angle between the moment of 1-ethyltetrazole and $\vec{\mu}_a$), must be positive and $\mu_a > 1.9$ while $\cos \theta_C$ (the angle between the moment of 2-ethyltetrazole and $\vec{\mu}_a$) must be negative.

If the foregoing treatment is correct, then one must conclude that $\vec{\mu}_A$ and $\vec{\mu}_C$ tend to be in opposite directions. The moment of (B) is larger than that of (A); therefore, these two moments tend to be in the same direction as the amino group moment. The amino group moment probably is directed toward the ring; therefore, the moment of 1-ethyltetrazole has the negative end of the dipole somewhat directed away from the ring carbon, and by the same reasoning the same would be true for tetrazole.

The measured dipole moments of 1,4-dimethyltetrazolone and 1,4-dimethyl-5-iminotetrazole are comparatively low, 1.14 and 1.65 *D*, respectively. From the structures indicated below one may again have difficulty in definitely stating whether or not the direction of the molecule's moment is augmented by the carbonyl.

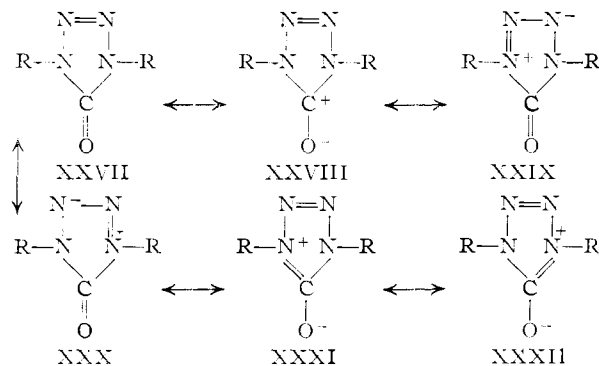

If the positive end of the tetrazole moment is at the carbon atom and structures such as XXVIII, XXXI and XXXII induce moments in an opposing direction, the direction of the tetrazolone moment still would not be determined; the direction would be reversed depending on whether the magnitude of the opposing dipole is four or six. If the negative end of the tetrazole moment is at the carbon, retaining the same line of reasoning, structures of the type XXIX and XXX oppose the tetrazole primary moment plus those of the structures XXVIII, XXXI and XXXII contributions by more than 4 *D*.

If we consider that 1,4-dimethyltetrazolone is a completely different system from tetrazole because two nitrogens have alkyl groups while a covalent structure (XXVII) can be drawn, we may then suggest that the moment is on the same line as the C=O linkage and probably in the same direction. Structures such as XXIX and XXX oppose in direction structures XXVIII, XXXI and XXXII to such an extent that the usually accepted value of the carbonyl link moment is reduced by approximately 50%.

If one considers that 1,4-dimethyl-5-iminotetra-

zole is a planar molecule (assuming that the imino hydrogen is, or nearly is, in the plane) and that the ring has a certain amount of aromatic character and therefore acts as an electron acceptor, another explanation may be suggested. The imino nitrogen has one orbital π to the ring forming the π part of the double bond. The lone pair of electrons of the imino nitrogen are also probably in the plane while the remaining available valence electron is available to the π orbital. Since the ring has properties of an electron acceptor, the electron tends to migrate into the ring making the ring negative with respect to the imino nitrogen.

The above type of argument may also be useful in connection with a discussion about 1,3 (or 2,4)-dimethyl-5-iminotetrazole. No conventional covalent structure can be written for this compound. It belongs to the group of substances which have been called cyclic "meso-ionic" compounds by Baker, *et al.*^{9,14}

Some structures which can be drawn for the free base (XXXIII-XXXVI) and the salt (XXXVII-XLI) are shown below.

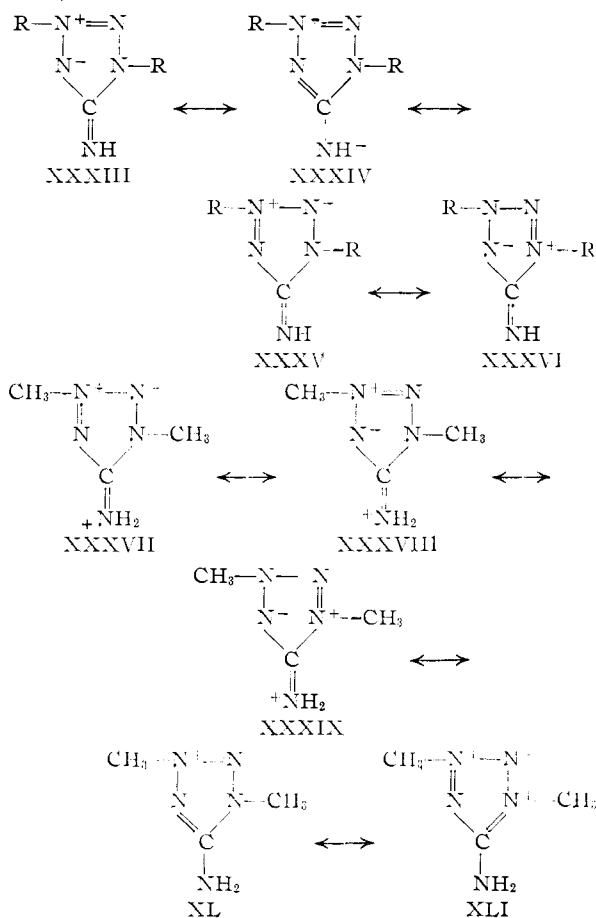

Since the apparent dipole moment of the free base is 4.02 *D*, the results of dipole moment measurement cannot be used as a criterion for establishing that a given compound is "meso-ionic" in the Baker¹⁴ sense (no conventional covalent structure can be written).

(14) W. Baker, W. D. Ollis, V. D. Poole, J. A. Barltrop, R. A. W. Hill and L. B. Sutton, *Nature*, **160**, 366 (1947).

A consideration of the resonance contributions to the hybrid structure of the free base would lead one to suspect that the negative end of the molecule's dipole moment is likely to be in the vicinity of the ring carbon or imino nitrogen.

Bryden's⁴ X-ray analysis of the salt is the basis for his conclusion that the major contributions to resonance come from structures XXXVII and XXXVIII, the other structural types contributing to a small extent. It is therefore quite likely that for the free base XXXIII and XXXV are most important and that XXXVI is not too important. Both XXXIII and XXXV suggest that the positive end of the dipole moment is at nitrogen three.

The difficulty which arises, however, is the lack of a complete explanation of why the moment of 1-ethyltetrazole is higher than the moment of this molecule. Perhaps structure XXXVI is of some importance giving a counteracting moment, or perhaps the ionic structures of 1-ethyltetrazole are as of great importance as the covalent structure.

If the foregoing is correct, one must ask why the dipole moment of 2-methyl-5-aminotetrazole is smaller than the moment of 1,3(or 2,4)-dimethyl-5-iminotetrazole by approximately 1.5 *D*. The approximate bond lengths in ångström units of the hydrobromide salt of the 1,3(or 2,4)-dimethyltetrazole and those of 2-methyl-5-aminotetrazole¹⁵ are given below

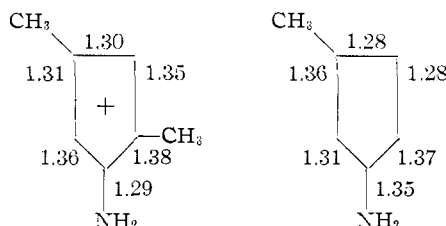

These bond lengths indicate that structures such as XXIII, XIIa and XXII probably offer major contributions to the over-all hybrid of 2-methyl-5-aminotetrazole. Here it appears as though the covalent structure of 2-methyl-5-aminotetrazole is as important as the ionic structures and, whereas in the "meso-ionic" compound the imino group moment augments, in 2-methyl-5-aminotetrazole it apparently has the opposite effect.

The molar heat of sublimation data¹⁶ for the tet-

(15) J. H. Bryden, unpublished results.

(16) H. W. Pitman, unpublished results.

razoles agree quite well with the measured dipole moments.

TABLE II
HEAT OF SUBLIMATION DATA

Tetrazole	μ 25° benzene	K cal.
2-Methyl-5-methylamino-	2.55	19.98
2-Methyl-5-amino-	~2.6	21.10
Tetrazole- ¹²	5.11 (dioxane)	21.45
1-Methyl-5-amino-	~7	25.75
1-Methyl-5-methylamino-	~7	26.32

These data are interesting in that they add evidence to the reasoning that the direction of the dipole moment of 2-alkyltetrazole is directed somewhat opposite to that of 1-alkyltetrazole, *i.e.*, by adding a methyl to the amino of 2-methyl-5-aminotetrazole, the ΔH_{sub} decreases, and adding a methyl to the amino of 1-methyl-5-aminotetrazole, the ΔH_{sub} increases.

Neither 1-methyl-5-aminotetrazole nor 2-methyl-5-aminotetrazole have steric effects influencing their dipole moments. The following data also show that there is little difference in the resonance energy of these two compounds.

TABLE III

Tetrazole	ENTHALPY DATA		
	$\Delta H_{\text{comb}}^{17}$ (kcal./m.)	ΔH_{sub} (kcal./ml.)	$\Delta H_{\text{comb. gas}}$ (kcal./m.)
1-Methyl-5-amino-	-404.7	25.75	-430.4
2-Methyl-5-amino-	-409.7	21.10	-430.8

The vapor pressure data of tetrazole seem to indicate that its dipole moment in benzene should be lower than the dioxane value of Jensen and Friediger.

It is also apparent from melting point data that intramolecular bonding to ring nitrogens by amino hydrogen is hindered by alkylating the amine if another allyl is in the one position.

Acknowledgments.—We wish to thank Drs. R. H. Henry and W. G. Finnegan for supplying the tetrazoles, Dr. R. Knipe whose interesting discussions and suggestions help make the presentation possible and Professor N. Davidson for critically reviewing this paper.

CHINA LAKE, CALIF.

(17) M. Williams and W. S. McEwan, unpublished results.